

# ROUTERS

## STANDARD LENGTH

*Diamond Cut*

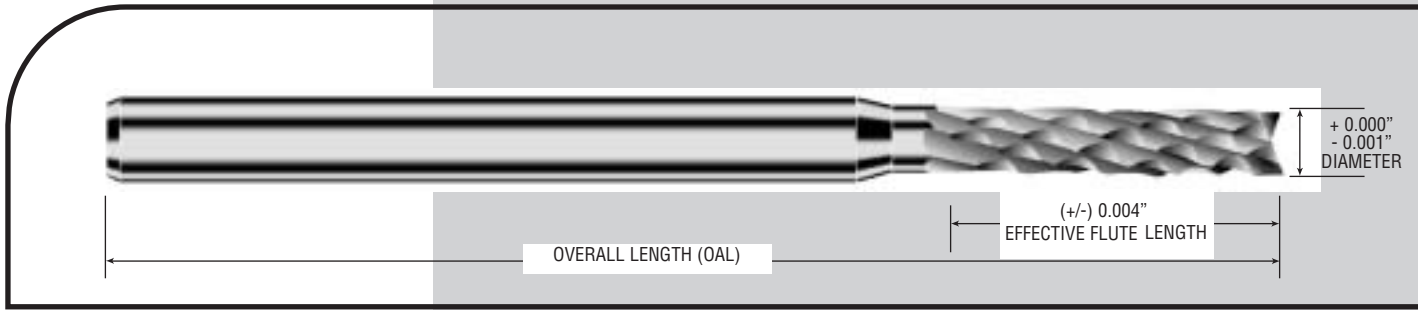

- Submicron Grade Carbide
- Diameter Tolerance + 0.000" / - 0.001"
- Fish Tail and Drill Point End Styles

### SERIES 2120 - FRACTIONS

PART NUMBER	CUTTING DIAMETER	EFFECTIVE FLUTE LENGTH	OVERALL LENGTH	SHANK DIAMETER	END STYLE	EDP
2120-0312.255F	1/32	.255	1 1/2	1/8	Fish Tail	12002
2120-0312.255D	1/32	.255	1 1/2	1/8	Drill Point	12003
2120-0469.255F	3/64	.255	1 1/2	1/8	Fish Tail	12005
2120-0469.255D	3/64	.255	1 1/2	1/8	Drill Point	12006
2120-0625.255F	1/16	.255	1 1/2	1/8	Fish Tail	12008
2120-0625.255D	1/16	.255	1 1/2	1/8	Drill Point	12009
2120-0938.395F	3/32	.395	1 1/2	1/8	Fish Tail	12011
2120-0938.395D	3/32	.395	1 1/2	1/8	Drill Point	12012
2120-1250.500F	1/8	.500	1 1/2	1/8	Fish Tail	12014
2120-1250.500D	1/8	.500	1 1/2	1/8	Drill Point	12015
2120-1875.2625F	3/16	.625	2	3/16	Fish Tail	12017
2120-1875.2625D	3/16	.625	2	3/16	Drill Point	12018
2120-2500.2750F	1/4	.750	2	1/4	Fish Tail	12020
2120-2500.2750D	1/4	.750	2	1/4	Drill Point	12021
2120-2500.3750F	1/4	.750	2 1/2	1/4	Fish Tail	12023
2120-2500.3750D	1/4	1	2 1/2	1/4	Drill Point	12024
2120-2500.4100F	1/4	1	3	1/4	Fish Tail	12026
2120-2500.4100D	1/4	1	3	1/4	Drill Point	12027