

# CENTER CUTTING END MILLS STANDARD LENGTH

4 Flute ■ Ball Nose

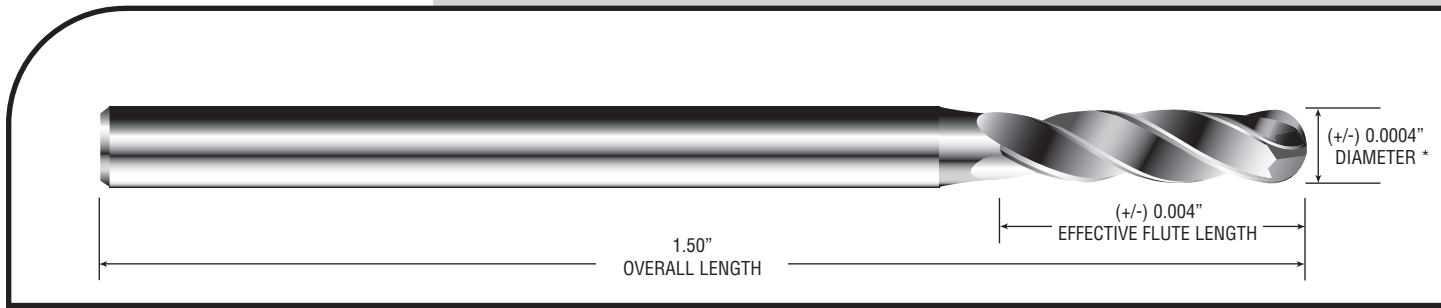

- Submicron grade carbide
- 30° helix for general purpose applications
- Coatings available upon request

## SERIES 1825 - FRACTIONS

| PART NUMBER   | CUTTING DIAMETER | EFFECTIVE FLUTE LENGTH | OVERALL LENGTH | SHANK DIAMETER | EDP   |
|---------------|------------------|------------------------|----------------|----------------|-------|
| 1825-0312.094 | 1/32             | .094                   | 1 1/2          | 1/8            | 82036 |
| 1825-0469.141 | 3/64             | .141                   | 1 1/2          | 1/8            | 82037 |
| 1825-0625.188 | 1/16             | .188                   | 1 1/2          | 1/8            | 82038 |
| 1825-0781.234 | 5/64             | .234                   | 1 1/2          | 1/8            | 82039 |
| 1825-0938.281 | 3/32             | .281                   | 1 1/2          | 1/8            | 82040 |
| 1825-1094.328 | 7/64             | .328                   | 1 1/2          | 1/8            | 82041 |
| 1825-1250.375 | 1/8              | .375                   | 1 1/2          | 1/8            | 82042 |
| 1825-1406.500 | 9/64             | .500                   | 2              | 3/16           | 82043 |
| 1825-1563.500 | 5/32             | .500                   | 2              | 3/16           | 82044 |
| 1825-1719.563 | 11/64            | .563                   | 2              | 3/16           | 82045 |
| 1825-1875.563 | 3/16             | .563                   | 2              | 3/16           | 82046 |
| 1825-2031.625 | 13/64            | .625                   | 2 1/2          | 1/4            | 82047 |
| 1825-2188.625 | 7/32             | .625                   | 2 1/2          | 1/4            | 82048 |
| 1825-2344.750 | 15/64            | .750                   | 2 1/2          | 1/4            | 82049 |
| 1825-2500.750 | 1/4              | .750                   | 2 1/2          | 1/4            | 82050 |

\* 9/64 or larger is + .000" / - .002"