

CENTER CUTTING END MILLS

STANDARD LENGTH

2 Flute ■ Ball Nose

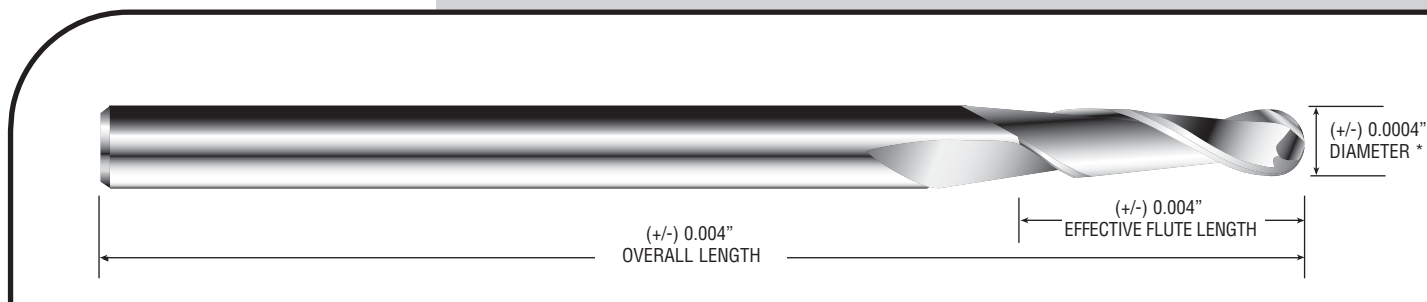

- Submicron grade carbide
- 30° helix for general purpose applications
- Coatings available upon request

SERIES 1625 - FRACTIONS

PART NUMBER	CUTTING DIAMETER	EFFECTIVE FLUTE LENGTH	OVERALL LENGTH	SHANK DIAMETER	EDP
1625-0156.047	1/64	.047	1 1/2	1/8	64056
1625-0312.094	1/32	.094	1 1/2	1/8	64041
1625-0469.141	3/64	.141	1 1/2	1/8	64042
1625-0625.188	1/16	.188	1 1/2	1/8	64043
1625-0781.234	5/64	.234	1 1/2	1/8	64044
1625-0938.281	3/32	.281	1 1/2	1/8	64045
1625-1094.328	7/64	.328	1 1/2	1/8	64046
1625-1250.375	1/8	.375	1 1/2	1/8	64047
1625-1406.500	9/64	.500	2	3/16	64048
1625-1562.500	5/32	.500	2	3/16	64049
1625-1719.563	11/64	.563	2	3/16	64050
1625-1875.563	3/16	.563	2	3/16	64051
1625-2031.625	13/64	.625	2 1/2	1/4	64052
1625-2188.625	7/32	.625	2 1/2	1/4	64053
1625-2344.750	15/64	.750	2 1/2	1/4	64054
1625-2500.750	1/4	.750	2 1/2	1/4	64055

SERIES 1625 - DECIMALS

PART NUMBER	CUTTING DIAMETER	EFFECTIVE FLUTE LENGTH	OVERALL LENGTH	SHANK DIAMETER	EDP
1625-0100.030	.010	.030	1 1/2	1/8	64006
1625-0150.045	.015	.045	1 1/2	1/8	64007
1625-0200.060	.020	.060	1 1/2	1/8	64008
1625-0250.075	.025	.075	1 1/2	1/8	64009
1625-0300.090	.030	.090	1 1/2	1/8	64010
1625-0350.105	.035	.105	1 1/2	1/8	64011
1625-0400.120	.040	.120	1 1/2	1/8	64012
1625-0450.135	.045	.135	1 1/2	1/8	64013
1625-0500.150	.050	.150	1 1/2	1/8	64014
1625-0550.165	.055	.165	1 1/2	1/8	64014
1625-0600.180	.060	.180	1 1/2	1/8	64016
1625-0650.195	.065	.195	1 1/2	1/8	64017
1625-0700.210	.070	.210	1 1/2	1/8	64018
1625-0750.225	.075	.225	1 1/2	1/8	64019
1625-0800.240	.080	.240	1 1/2	1/8	64020
1625-0850.255	.085	.255	1 1/2	1/8	64021
1625-0900.270	.090	.270	1 1/2	1/8	64022
1625-0950.285	.095	.285	1 1/2	1/8	64023
1625-1000.300	.100	.300	1 1/2	1/8	64024

* 9/64 or larger is + .000" / - .002"

MICRO TOOLS

Tools individually packed