

ENGRAVING/SPADE TOOLS

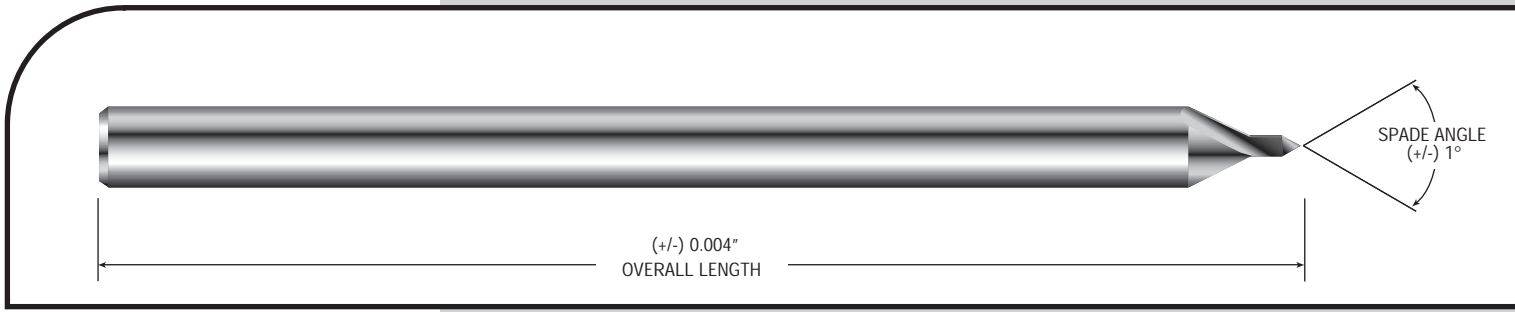

- Submicron Grade Carbide
- 1/8" Shank

SERIES EGR1250 - 2 FLUTE ENGRAVING TOOLS

PART NUMBER	SHANK DIAMETER	SPADE ANGLE	OVERALL LENGTH	EDP
EGR1250-030	1/8	30°	1 1/2	85001
EGR1250-060	1/8	60°	1 1/2	85002
EGR1250-090	1/8	90°	1 1/2	85003

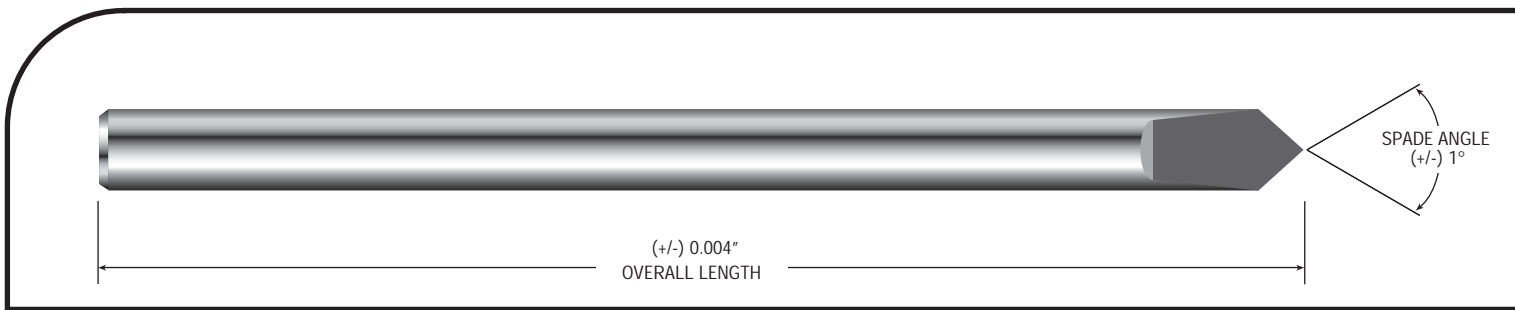

- Submicron Grade Carbide
- 1/8" Shank

SERIES SPD1250 - SPADE TOOLS

PART NUMBER	SHANK DIAMETER	SPADE ANGLE	OVERALL LENGTH	EDP
SPD1250-030	1/8	30°	1 1/2	85004
SPD1250-045	1/8	45°	1 1/2	85005
SPD1250-060	1/8	60°	1 1/2	85006
SPD1250-090	1/8	90°	1 1/2	85007
SPD1250-118	1/8	118°	1 1/2	85008

MICRO TOOLS

Tools individually packed

For additional information call 1-888-848-8449 or visit us at www.KyoceraMicroTools.com